



**OPERATOR'S MANUAL**

A Division of Snow Joe®, LLC

**CORDLESS DRILL/DRIVER**  
24-VOLT MAX\* | 2.0 Ah | TOOL CASE

**Model 24V-DD-LTE-RM**

Form No. SJ-24V-DD-LTE-RM-880E-M-V1

**THANKS FOR YOUR PURCHASE  
OF A REMANUFACTURED PRODUCT.**

To make sure you get the most out of your product, be sure to register online at

**sunjoe.com**

to enjoy full product support.

PASTE UPC LABEL HERE



## OPERATOR'S MANUAL

A Division of Snow Joe®, LLC

# CORDLESS DRILL/DRIVER

24-VOLT MAX\* | 2.0 Ah | TOOL CASE

Model 24V-DD-LTE-RM

Form No. SJ-24V-DD-LTE-RM-880E-M-V1

## IMPORTANT!

### Safety Instructions

### All Operators Must Read These Instructions Before Use

Always follow these safety guidelines. Failure to do so may result in serious bodily injury or death.

### General Safety

**⚠️ WARNING!** When using the drill/driver basic safety precautions should always be followed to reduce the risk of fire, electric shock, and personal injury. These include:

#### Work Area Safety

1. **Keep work area clean and well-lit** – Cluttered, dark areas invite accidents.
2. **Keep children, bystanders, and pets away** – All spectators, including pets, should be kept a safe distance away from the work area.
3. **Do not operate power tools in explosive atmospheres** – Such as in the presence of flammable liquids, gases, or dust. Power tools create sparks which may ignite the dust or fumes.

#### Personal Safety

1. **Stay alert** – Watch what you are doing. Use common sense. Do not operate the drill/driver when you are tired, or under the influence of alcohol or drugs.
2. **Dress properly** – Do not wear loose clothing or jewelry. They can get caught in moving parts. Loose clothes, jewelry, or long hair can be caught in moving parts.
3. **Avoid unintentional starting** – Do not carry the drill/driver with your finger on the trigger. Make sure the switch is off before connecting the drill/driver to power source.
4. **Do not overreach** – Keep proper footing and balance at all times. Proper footing and balance enable better control of the cordless drill/driver in unexpected situations.
5. **Use personal protective equipment** – Always wear eye protection. Protective equipment such as dust mask, non-skid safety shoes, hard hat, or hearing protection used for appropriate conditions will reduce personal injuries.

6. **If devices are provided for the connection of dust extraction and collection facilities, ensure these are connected and properly used.** – Use of dust collection can reduce dust-related hazards.
7. **Do not use on a ladder or unstable support** – Stable footing on a solid surface enables better control of the power tool in unexpected situations.

#### Tool Use and Care

1. **Do not force the tool** – It will perform better with less likelihood of personal or mechanical injury if it is used at the rate for which it was designed.
2. **Do not use drill/driver if switch does not turn on or off** – The drill/driver that cannot be controlled with the switch is dangerous and must be repaired.
3. **Disconnect the plug from the power source and/or battery pack from the drill/driver before making any adjustments, changing accessories, or storing the drill/driver** – Such preventive safety measures reduce risk of starting the power tool accidentally.
4. **Store idle drill/driver out of reach of children or other untrained persons** – Drill/driver is dangerous in the hands of untrained users.
5. **Maintain cordless drill/driver** – Check for misalignment or binding of moving parts, breakage of parts, and any other condition that may affect the drill/driver's operation. If damaged, have the drill/driver serviced before using. Many accidents are caused by poorly maintained tools.
6. **Use the power tool, accessories and tool bits etc. in accordance with these instructions, taking into account the working conditions and the work to be performed** – Use of the power tool for operations different from those intended could result in a hazardous situation.

#### Battery Tool Use and Care

1. **Recharge only with the charger specified by the manufacturer** – A charger that is suitable for one type of battery pack may create a risk of fire when used with another battery pack.
2. **Charge internal battery at ambient temperatures between 50°F – 104°F (10°C – 40°F).**
3. **Under abusive conditions, liquid may be ejected from the battery; avoid contact. If contact accidentally occurs, flush with water. If liquid contacts eyes, seek medical help** – Liquid ejected from the battery may cause irritation or burns.

4. **Use power tools only with specifically designated battery packs** – Use of any other battery packs may create a risk of injury and fire.
5. **When battery pack is not in use, keep it away from other metal objects, like paper clips, coins, keys, nails, screws or other small metal objects, that can make a connection from one terminal to another** – Shorting the battery terminals together may cause burns or a fire.

## Service

1. **If your power tool requires service, contact an authorized Snow Joe® + Sun Joe® dealer or call the Snow Joe® + Sun Joe® customer service center at 1-866-SNOWJOE (1-866-766-9563)** – Only identical replacement parts should be utilized for repairs. This will ensure that the safety of the power tool is maintained.
2. **If the battery charger cable is damaged, it must be immediately replaced to avoid a hazard** – Contact the Snow Joe® + Sun Joe® customer service center at 1-866-SNOWJOE (1-866-766-9563) for assistance.

## Safety Rules for Cordless Drill/Driver

1. **Hold power tool by insulated gripping surfaces, when performing an operation where the cutting accessory may contact hidden wiring** – Cutting accessory contacting a “live” wire may make exposed metal parts of the power tool “live” and could give the operator an electric shock.
2. **Know your power tool. Read operator’s manual carefully. Learn its applications and limitations, as well as the specific potential hazards related to this power tool** – Following this rule will reduce the risk of electric shock, fire, or serious injury.
3. **Make sure approved eye protection is being worn and properly adjusted and secured at all times the drill/driver is being used** – There is a possibility that small pieces of metal could shear off from over-tightened screws while using the tool.
4. **Protect your lungs. Wear a face or dust mask if the operation is dusty** – Following this rule will reduce the risk of serious personal injury.
5. **Protect your hearing. Wear hearing protection during extended periods of operation** – Following this rule will reduce the risk of serious personal injury.
6. **Battery tools do not have to be plugged into an electrical outlet; therefore, they are always in operating condition. Be aware of possible hazards when not using your battery tool or when changing accessories** – Following this rule will reduce the risk of electric shock, fire, or serious personal injury.
7. **Do not place battery tools or their batteries near fire or heat** – This will reduce the risk of explosion and possibly injury.

8. **Do not crush, drop or damage battery pack. Do not use a battery pack or charger that has been dropped or received a sharp blow** – A damaged battery is subject to explosion. Properly dispose of a dropped or damaged battery immediately.
9. **Batteries can explode in the presence of a source of ignition, such as a pilot light** – To reduce the risk of serious personal injury, never use any cordless product in the presence of open flame. An exploded battery can propel debris and chemicals. If exposed, flush with water immediately.
10. **Do not charge battery tool in a damp or wet location** – Following this rule will reduce the risk of electric shock.

## Battery + Charger Safety Instructions

We pay a great deal of attention to the design of every battery pack to ensure that we supply you with batteries that are safe, durable and have a high energy density. The battery cells have a wide range of safety devices. Each individual cell is initially formatted and its electrical characteristic curves are recorded. This data is then used exclusively to be able to assemble the best possible battery packs.

Despite all the safety precautions, caution must always be exercised when handling batteries. The following points must be obeyed at all times to ensure safe use. Safe use can only be guaranteed if undamaged cells are used. Incorrect handling of the battery pack can cause cell damage.

**IMPORTANT!** Analyses confirm that incorrect use and poor care of high-performance batteries are the main factors responsible for personal and/or product damage.

**⚠️ WARNING!** Use only approved replacement batteries; other batteries may damage the cordless drill/driver and cause it to malfunction, which can lead to serious personal injury.

**⚠️ CAUTION!** To reduce the risk of injury, charge the iON+ 24V lithium-ion battery pack only in its designated iON+ 24V lithium-ion charger. Other types of chargers present risk of fire, personal injury and damage. Do not wire a battery pack to a power supply plug or car cigarette lighter. Such misuse will permanently disable or damage the battery pack.

- **Avoid dangerous environments** – Do not charge the battery pack in rain, snow or in damp or wet locations. Do not use the battery pack or charger in the presence of explosive atmospheres (gaseous fumes, dust or flammable materials) because sparks may be generated when inserting or removing the battery pack, which could lead to a fire.
- **Charge in a well-ventilated area** – Do not block the charger vents. Keep them clear to allow for proper ventilation. Do not allow smoking or open flames near a charging battery pack. Vented gases may explode.

**NOTE:** The safe temperature range for the battery is 41°F – 105°F (5°C – 40.5°C). Do not charge the battery outside in freezing weather; charge it at room temperature.

- **Maintain charger cord** – When unplugging the charger, pull the plug, not the cord, from the receptacle to reduce the risk of damage to the electrical plug and cord. Never carry the charger by its cord or yank it by the cord to disconnect it from the receptacle. Keep the cord away from heat, oil and sharp edges. Make sure the cord will not be stepped on, tripped over or subjected to damage or stress when the charger is in use. Do not use the charger with a damaged cord or plug. Replace a damaged charger immediately.
- **Do not use an extension cord unless it is absolutely necessary** – Using the wrong, damaged or improperly wired extension cord poses a risk of fire and electric shock. If an extension cord must be used, plug the charger into a properly wired 16 gauge or larger extension cord with the female plug matching the male plug on the charger. Make sure that the extension cord is in good electrical condition.
- **Use only recommended attachments** – Use of an attachment not recommended or sold by the battery charger or battery pack manufacturer may result in risk of fire, electric shock or personal injury.
- **Unplug charger when not in use** – Make sure to remove battery packs from unplugged chargers.

 **WARNING!** To reduce the risk of electric shock, always unplug the charger before performing any cleaning or maintenance. Do not allow water to flow into the charger. Use a Ground Fault Circuit Interrupter (GFCI) to reduce shock hazards.

- **Do not burn or incinerate battery packs** – Battery packs may explode, causing personal injury or damage. Toxic fumes and materials are created when battery packs are burned.
- **Do not crush, drop or damage battery packs** – Do not use the battery pack or charger if they have sustained a sharp blow, been dropped, run over or have been damaged in any way (i.e. pierced with a nail, hit with a hammer, stepped on, etc.).
- **Do not disassemble** – Incorrect reassembly may pose a serious risk of electric shock, fire or exposure to toxic battery chemicals. If the battery or charger are damaged, contact an authorized Snow Joe® + Sun Joe® dealer or call the Snow Joe® + Sun Joe® customer service center at 1-866-SNOWJOE (1-866-766-9563) for assistance.
- **Battery chemicals cause serious burns** – Never let a damaged battery pack contact the skin, eyes or mouth. If a damaged battery pack leaks battery chemicals, use rubber or neoprene gloves to safely dispose of it. If skin is exposed to battery fluids, wash the affected area with soap and water and rinse with vinegar. If eyes are exposed to battery chemicals, immediately flush with water for 20 minutes and seek medical attention. Remove and dispose of contaminated clothing.
- **Do not short circuit** – When battery pack is not in use, keep it away from other metal objects, like paper clips, coins, keys, nails, screws or other small metal objects, that can make a connection from one terminal to another. Shorting the battery terminals together may cause burns or a fire.

- **Store your battery pack and charger in a cool, dry place** – Do not store the battery pack or charger where temperatures may exceed 105°F (40.5°C), such as in direct sunlight or inside a vehicle or metal building during the summer.

## Information about the battery

1. The battery pack supplied with your cordless power tool is only partially charged. The battery pack has to be charged completely before you use the tool for the first time.
2. For optimum battery performance, avoid low discharge cycles by charging the battery pack frequently.
3. Store the battery pack in a cool place, ideally at 77°F (25°C) and charged to at least 40%.
4. Lithium-ion batteries are subject to a natural aging process. The battery pack must be replaced at the latest when its capacity falls to just 80% of its capacity when new. Weakened cells in an aged battery pack are no longer capable of meeting the high power requirements needed for the proper operation of your cordless drill/driver, and therefore pose a safety risk.
5. Do not throw battery packs into an open fire as this poses a risk of explosion.
6. Do not ignite the battery pack or expose it to fire.
7. Do not exhaustively discharge batteries. Exhaustive discharge will damage the battery cells. The most common cause of exhaustive discharge is lengthy storage or non-use of partially discharged batteries. Stop working as soon as the performance of the battery falls noticeably or the electronic protection system triggers. Place the battery pack in storage only after it has been fully charged.
8. Protect batteries and the tool from overloads. Overloads will quickly result in overheating and cell damage inside the battery housing even if this overheating is not apparent externally.
9. Avoid damage and shocks. Immediately replace batteries that have been dropped from a height of more than 3 feet (1 meter) or those that have been exposed to violent shocks, even if the housing of the battery pack appears to be undamaged. The battery cells inside the battery may have suffered serious damage. In such instances, please read the waste disposal information for proper battery disposal.
10. If the battery pack suffers overloading and overheating, the integrated protective cutoff will switch off the equipment for safety reasons.  
**IMPORTANT!** Do not press the ON/OFF switch any more if the protective cut-off has been activated. This may damage the battery pack.
11. Recharge only with the charger specified by the manufacturer. A charger that is suitable for one type of battery pack may create a risk of fire when used with another battery pack.
12. Use appliances only with specifically designated battery packs. Use of any other battery packs may create a risk of injury and fire.







13. Under abusive conditions, liquid may be ejected from the battery; avoid contact. If contact accidentally occurs, flush with water. If liquid contacts eyes, additionally seek medical help. Liquid ejected from the battery may cause irritation or burns. (This advice is considered correct for conventional NiMh, NiCd, lead acid and lithium-ion cell types. If this advice is incorrect for a cell design that differs from these, then the correct advice may be substituted.)
14. Do not use a battery pack or appliance that is damaged or modified. Damaged or modified batteries may exhibit unpredictable behavior resulting in fire, explosion or risk of injury.
15. Do not expose a battery pack or appliance to fire or excessive temperature. Exposure to fire or temperature above 266°F (130°C) may cause explosion.
16. Follow all charging instructions and do not charge the battery pack or appliance outside of the temperature range specified in the instructions. Charging improperly or at temperatures outside of the specified range may damage the battery and increase the risk of fire.
8. Never use or charge batteries if you suspect that it has been more than 12 months since the last time they were charged. There is a high probability that the battery pack has already suffered dangerous damage (exhaustive discharge).
9. Charging batteries at a temperature below 41°F (5°C) will cause chemical damage to the cells and may cause a fire.
10. Do not use batteries that have been exposed to heat during the charging process, as the battery cells may have suffered dangerous damage.
11. Do not use batteries that have suffered curvature or deformation during the charging process or those that exhibit other atypical symptoms (gassing, hissing, cracking, etc.).
12. Never fully discharge the battery pack (maximum recommended depth of discharge is 80%). A complete discharge of the battery pack will lead to premature aging of the battery cells.

## Information about the charger and the charging process

1. Please check the data marked on the rating plate of the battery charger. Be sure to connect the battery charger to a power supply with the voltage marked on the rating plate. Never connect it to a different mains voltage.
2. Protect the battery charger and its cord from damage. Keep the charger and its cord away from heat, oil and sharp edges. Have damaged cords repaired without delay by a qualified technician at an authorized Snow Joe® + Sun Joe® dealer or call the Snow Joe® + Sun Joe® customer service center at 1-866-SNOWJOE (1-866-766-9563).
3. Electrical plugs must match the outlet. Never modify the plug in any way. Do not use any adapter plugs with grounded appliances. Unmodified plugs and matching outlets will reduce the risk of electric shock.
4. Keep the battery charger, battery pack(s) and the cordless tool out of the reach of children.
5. Do not use the supplied battery charger to charge other cordless tools.
6. During periods of heavy use, the battery pack will become warm. Allow the battery pack to cool to room temperature before inserting it into the charger to recharge.
7. Do not overcharge batteries. Do not exceed the maximum charging times. These charging times only apply to discharged batteries. Frequent insertion of a charged or partially charged battery pack will result in overcharging and cell damage. Do not leave batteries in the charger for days on end.
1. Wear suitable work clothes. Wear safety goggles.
2. Protect your cordless tool and the battery charger from moisture and rain. Moisture and rain can cause dangerous cell damage.
3. Do not use the cordless tool or the battery charger near vapors and flammable liquids.
4. Use the battery charger and cordless tools only in dry conditions and at an ambient temperature of 41°F – 105°F (5°C – 40.5°C).
5. Do not keep the battery charger in places where the temperature is liable to reach over 105°F (40.5°C). In particular, do not leave the battery charger in a car that is parked in the sunshine.
6. Protect batteries from overheating. Overloads, overcharging and exposure to direct sunlight will result in overheating and cell damage. Never charge or work with batteries that have been overheated – replace them immediately, if possible.
7. Store the charger and your cordless tool only in dry locations with an ambient temperature of 41°F – 105°F (5°C – 40.5°C). Store your lithium-ion battery pack in a cool, dry place at a temperature of 77°F (25°C). Protect the battery pack, charger and cordless tool from humidity and direct sunlight. Only place fully charged batteries in storage (charged to at least 40%).
8. Prevent the lithium-ion battery pack from freezing. Battery packs that were stored below 32°F (0°C) for more than 60 minutes must be discarded.
9. When handling batteries, be wary of electrostatic charge. Electrostatic discharges can damage the electronic protection system and the battery cells. Avoid electrostatic charging and never touch the battery poles.

# Safety Symbols

The following table depicts and describes safety symbols that may appear on this product. Read, understand, and follow all instructions on the machine before attempting to assemble and operate.

Symbols	Descriptions	Symbols	Descriptions
	<b>READ THE OPERATOR'S MANUAL(S)</b> – Read, understand, and follow all instructions in the user manual(s) before attempting to assemble and operate.		<b>SAFETY ALERT</b> – Indicates a precaution, a warning, or a danger.
	<b>WARNING!</b> Do not expose the unit to rain or wet conditions. Keep dry.		<b>WEAR EYE PROTECTION</b> – For protection against injury, wear safety goggles.
	<b>WET CONDITIONS ALERT</b> – Do not expose to rain or use in damp locations.		Indoor use only. Only use battery charger indoors.
	<b>DISPOSAL</b> – Waste produced by electrical machine items should not be handled like normal household rubbish. Please recycle where recycle facilities exist. Check with your local authority or retailer for recycling advice.		

# Know Your Cordless Drill/Driver

Read the owner's manual and safety instructions carefully before operating the cordless drill/driver. Compare the illustration below to the cordless drill/driver in order to familiarize yourself with the location of the various controls and adjustments. Save this manual for future reference.

1. Keyless chuck
2. Torque adjustment ring
3. Two-speed gear train (high – low)
4. Level
5. Air vent
6. Direction of rotation selector (forward/reverse/center lock)
7. Trigger switch
8. LED light
9. Bit storage
10. Built-in magnetic screw tray
11. Battery compartment
12. Double-ended driver bit
13. Battery indicators
14. Push button for battery indicator
15. Push lock button
16. 24V iON+ lithium-ion battery (24VBAT-LTE) featuring exclusive EcoSharp® technology
17. Charger plug
18. Charger indicator lights
19. Charger socket
20. 24V iON+ lithium-ion battery quick charger (24VCHRG-QC)
21. Tool case

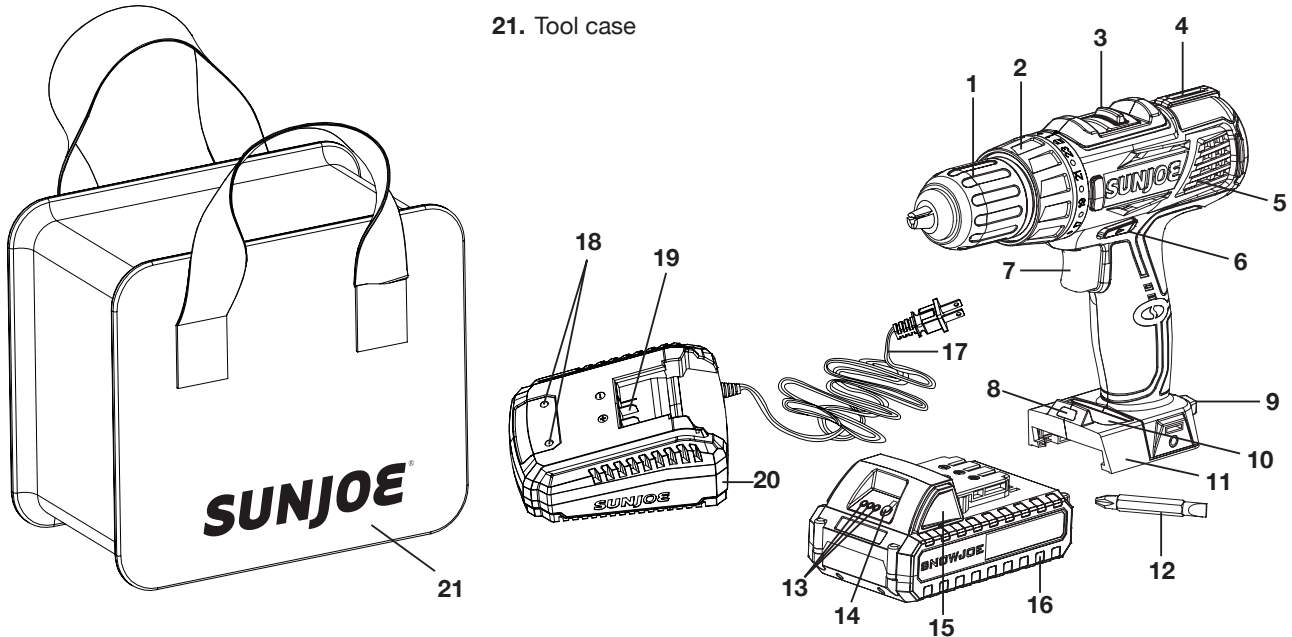

## Technical Data

Battery Voltage Max* .....	24V D.C.	Drill Bit Size Max .....	0.5 in. (13 mm)
Battery Capacity .....	2.0 Ah	Double-ended Bit .....	S2 & PH2 0.25 in. (6.35 mm)
Charger Input .....	120V AC, 60 Hz, 75 W	Chuck Size .....	0.5 in. (13 mm)
Charger Output .....	26V D.C. $\overline{\text{---}}$ 2200 mA	Chuck Type .....	Keyless
Charge Time Max .....	55 min	Clutch Settings .....	23 screw settings + 1 drill setting
No Load Speed .....	Low – 350 rpm High – 1400 rpm	Selector Settings .....	Forward + reverse
Torque .....	265 in-lbs	LED Light .....	1 watt
Speed Settings .....	2-speed	Net Weight .....	5 lbs (2.3 kg)

\*Initial no-load voltage, when fully charged, peaks at 24 volts; nominal voltage under typical load is 21.6 volts.

# Unpacking

## Carton Contents

- Cordless drill/driver
- Double-ended driver bit
- 24V iON+ lithium-ion battery
- 24V iON+ lithium-ion battery quick charger
- Tool case
- Manual with registration card

1. Carefully remove the cordless drill/driver and check to see that all of the above items are supplied.
2. Inspect the product carefully to make sure no breakage or damage occurred during shipping. If you find damaged or missing parts, DO NOT return the unit to the store. Please call the Snow Joe® + Sun Joe® customer service center at 1-866-SNOWJOE (1-866-766-9563).

**NOTE:** Do not discard the shipping carton and packaging material until you are ready to use your new cordless drill/driver. The packaging is made of recyclable materials. Properly dispose of these materials in accordance with local regulations.

**IMPORTANT!** The equipment and packaging material are not toys. Do not let children play with plastic bags, foils, or small parts. These items can be swallowed and pose a suffocation risk!

## Battery Pack Operation





The equipment is powered by a lithium-ion battery. The battery pack is completely sealed and maintenance free.

**⚠ WARNING!** Before first use, the battery requires at least 55 mins charge time to be fully charged. Recharge for 55 mins again before resuming operation.

### Battery Charge Level Indicator

The battery pack is equipped with a push button for checking the charge level. Simply press the push button to read off the battery charge level from the LEDs of the battery indicator:

- All 3 level monitoring LEDs are lit: Battery charge level is high.
- 2 level monitoring LEDs are lit: Battery charge level is decreasing. Stop work as soon as possible.
- 1 level monitoring LED is lit: Battery is flat. Stop work IMMEDIATELY and charge the battery. Otherwise the battery's service life will be greatly shortened.

Lights	Light Indicators
	Charge level button
	The battery is at 30% capacity and requires charging
	The battery is at 60% capacity and requires charging soon
	The battery is at full capacity

**NOTE:** If the charge level button does not appear to be working, insert the charger and charge as needed.

**NOTE:** Immediately after using the battery pack, the charge level button may display a lower charge than it will if checked a few minutes later. The battery cells "recover" some of their charge after resting.

## Charger Operation

**⚠ WARNING!** Charge only 24V iON+ lithium-ion battery packs with its compatible 24V iON+ lithium-ion quick charger. Other types of batteries may cause personal injury and damage.

To reduce the risk of electric shock, do not allow water to flow into the charger's AC/DC plug.

### When to Charge the iON+ 24VBAT-LTE Lithium-Ion Battery

**NOTE:** The iON+ 24VBAT-LTE lithium-ion battery packs do not develop a "memory" when charged after only a partial discharge. Therefore, it is not necessary to run down the battery pack before placing it into the charger.

- Use the battery charge indicator lights to determine when to charge your iON+ 24VBAT-LTE lithium-ion battery pack.
- You can "top-off" your battery pack's charge before starting a big job or after a long day of use.



## Charging the Battery

1. Push the push lock button on the battery to pull the battery pack out of the equipment (Fig. 1).

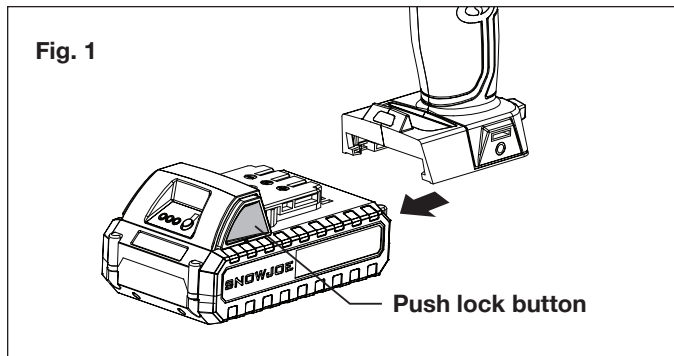

2. Check that the mains voltage is the same as that marked on the rating plate of the battery charger. Then, insert the charger's plug into the electrical wall outlet. When you plug in the charger, the top right green light will illuminate and stay green (Fig. 2).

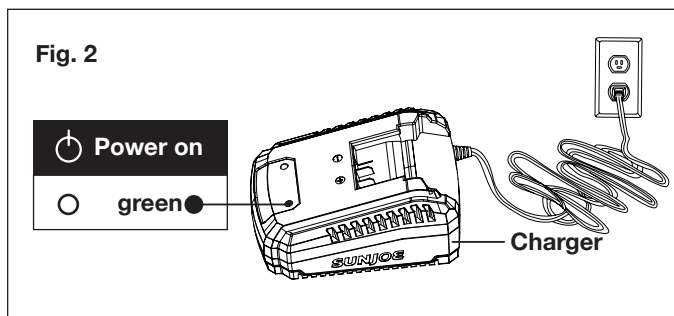

3. Place the battery pack into the charger by sliding the pack as shown to lock it into position. When you insert the battery into the charger, the top right green light will go off, and the top left red light will illuminate to indicate that the battery is charging (Fig. 3).

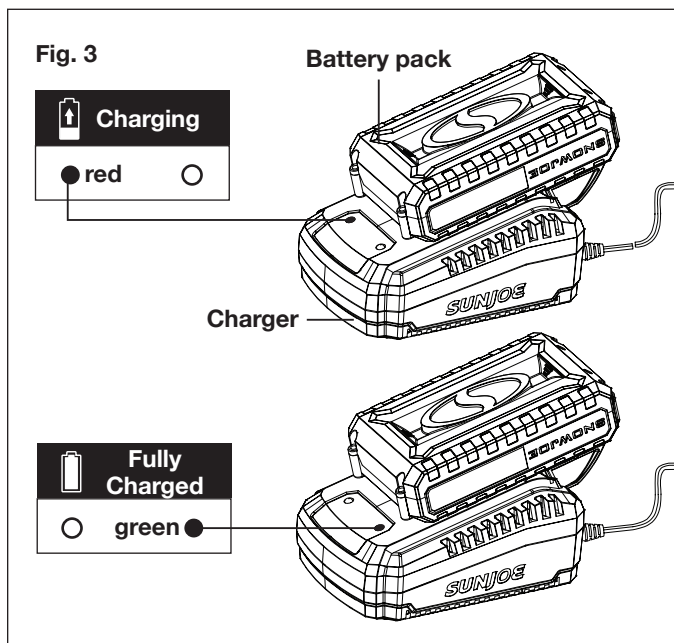

4. When the charger light turns green, the battery is fully charged (Fig. 3).
5. A fully discharged pack with an internal temperature in the normal range will fully charge in 55 mins (between 32°F/0°C and 113°F/45°C).
6. If the light indicators do not come on at all, check that the battery pack is fully seated into the bay. Remove the battery pack and reinsert. If the problem persists, contact an authorized Snow Joe® + Sun Joe® dealer or call the Snow Joe® + Sun Joe® customer service center at 1-866-SNOWJOE (1-866-766-9563) for assistance.
7. When charging is complete, remove the battery from the charger by pulling the push lock button and sliding the battery backward to unlock it from the charger (Fig. 4).

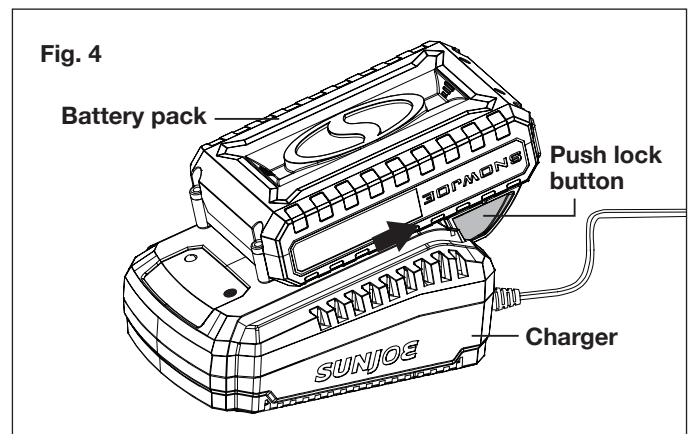

8. Timely recharging of the battery will help prolong the battery's life. You must recharge the battery pack when you notice a drop in the equipment's power.

**IMPORTANT!** Never allow the battery pack to become fully discharged as this will cause irreversible damage to the battery.

## Charging a Hot or Cold Battery Pack

The green indicator light on the charger base indicates that the battery pack temperature is outside the charging range. Once the pack is within the acceptable range, normal charging will take place and the red light will be continuous. Hot or cold battery packs may take longer to charge.

Lithium-Ion Charging Status			
Battery Pack Temperature	Charger Base Indicator Light	Battery Pack Indicator Light	Charging Status
Too hot	Green	Flashing together	Not charging
Normal range	Red	Flashing one by one	Normal charging
Too cold	Green	Flashing together	Not charging

# Assembly

**⚠️WARNING!** Always remove battery pack from the tool when you are assembling parts, making adjustments, cleaning, or when not in use. Removing battery pack will prevent accidental starting that could cause serious personal injury.

**⚠️WARNING!** Do not use any attachments or accessories not recommended by the manufacturer of this product. The use of attachments or accessories not recommended can result in serious personal injury.

## Applications

You may use this drill/driver for the purposes listed below:

- Drilling in all types of wood products (lumber, plywood, paneling, composition board, and hard board), ceramics, plastics, fiberglass, laminates, and metals; driving screws into wood and drywall with screwdriver bits.

# Operation

## Installing + Removing Drill Bits

The arrows on the keyless chuck indicate which direction to rotate the chuck sleeve to tighten or release the drill bit.

Do not use a wrench to tighten or loosen the chuck jaws.

1. To install bits, set the direction of rotation selector in the LOCK (center lock) position to lock the switch trigger (Fig. 5).

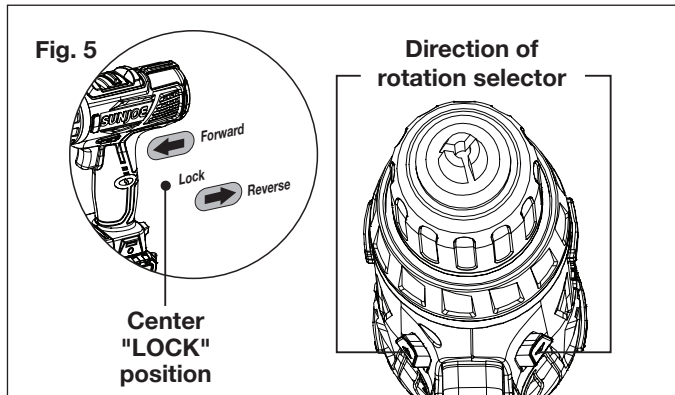

2. Rotate the chuck sleeve counterclockwise to open the chuck jaws until the opening is slightly larger than the bit size you intend to use (Fig. 6).

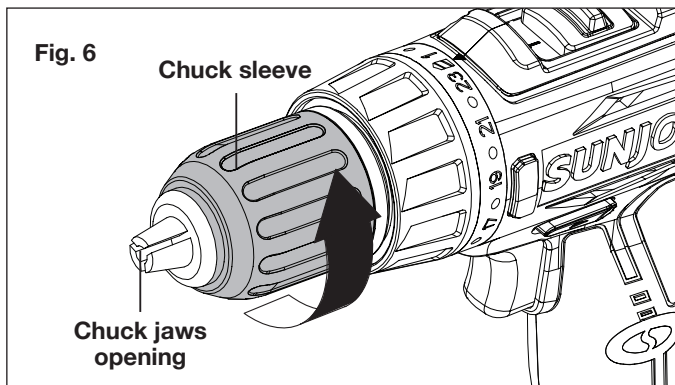

3. Raise the front of the drill slightly and insert the double-ended driver bit or drill bit (Fig. 7).

**NOTE:** Drill bit is not included.

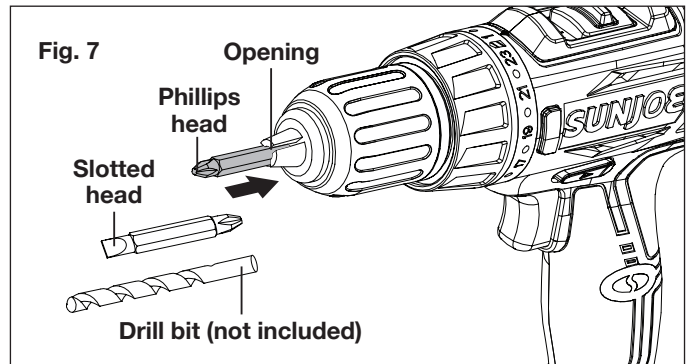

**⚠️WARNING!** Make sure to insert the driver bit/drill bit straight into the chuck jaws. Do not insert the driver bit/drill bit into the chuck jaws at an angle, then tighten. This could cause the driver bit/drill bit to be thrown from the drill, resulting in possible serious personal injury or damage to the chuck (Fig. 8).

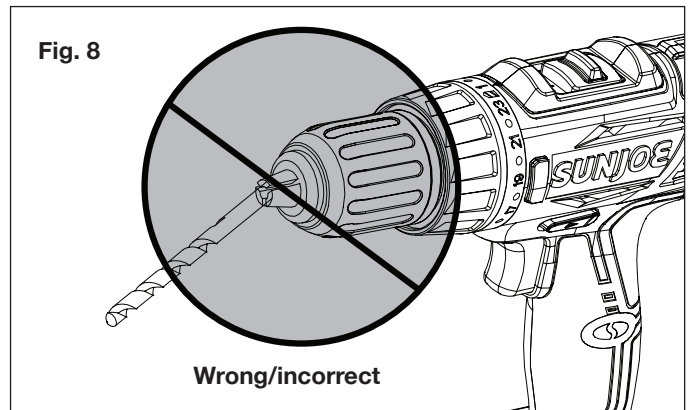

4. Rotate the chuck sleeve clockwise to close and tighten the chuck jaws (Fig. 9).

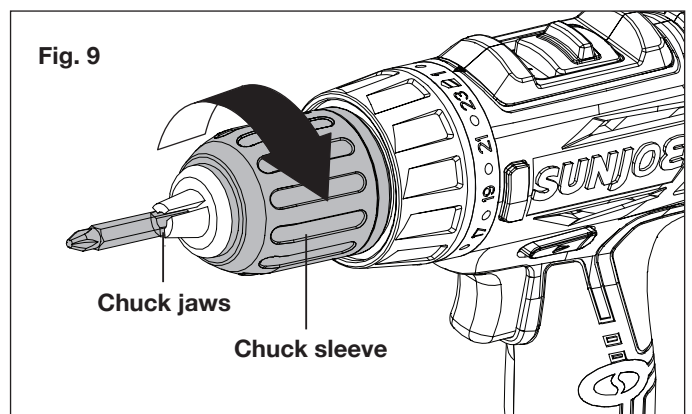

**⚠️WARNING!** Do not hold the chuck sleeve with one hand and use the power of the drill to tighten the chuck jaws on the driver bit/drill bit. The chuck sleeve could slip in your hand, or your hand could slip and come in contact with the rotating driver bit/drill bit. This could cause an accident resulting in serious personal injury.

5. To remove bits, lock the switch trigger and open the chuck jaws (Fig. 6).
6. The bit provided with the drill can be placed in the storage area, located on the base of the drill (Fig. 10).

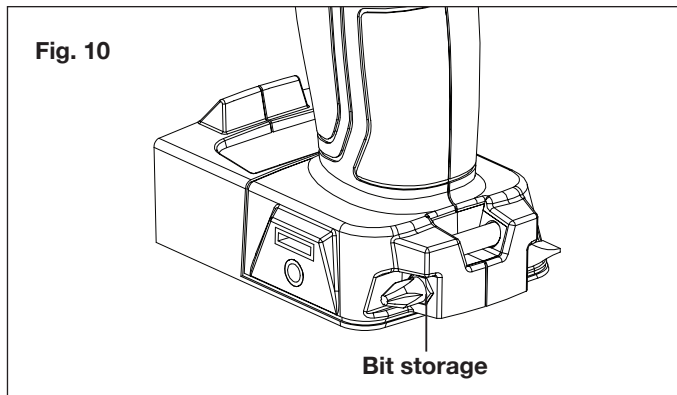

3. The center position locks the tool (Fig. 13).

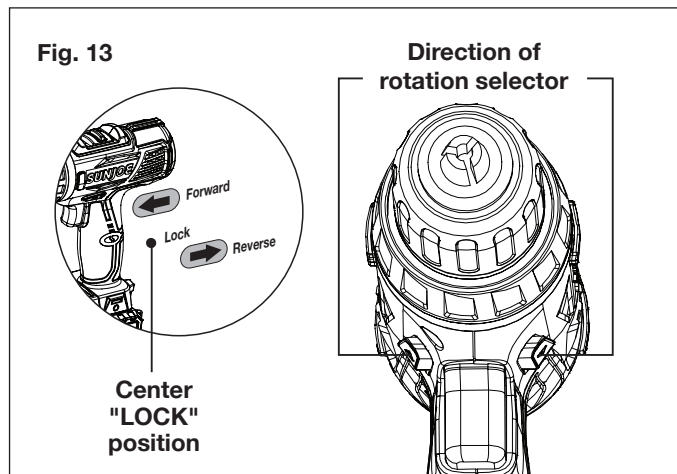

## Selecting the Direction of Rotation

**⚠ WARNING!** Set the direction of rotation selector in the OFF (center lock) position to lock the switch trigger and help prevent accidental starting when not in use.

**NOTE:** Always check the direction of the cordless drill/driver rotation before use.

1. To select forward rotation, press the forward selector switch from right to left flat against the cordless drill/driver (Fig. 11).

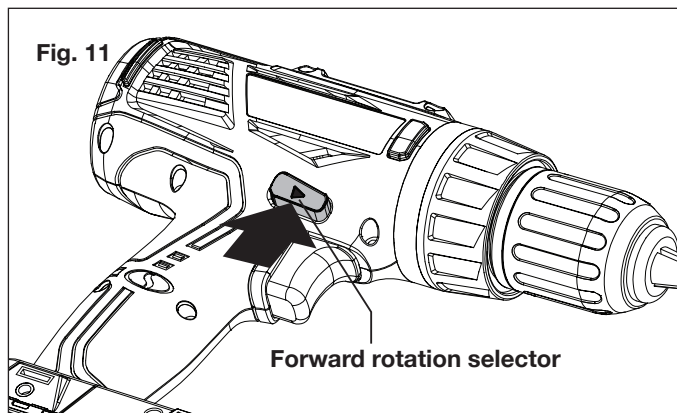

2. To select reverse rotation, press the reverse selector switch in the opposite direction (Fig. 12).

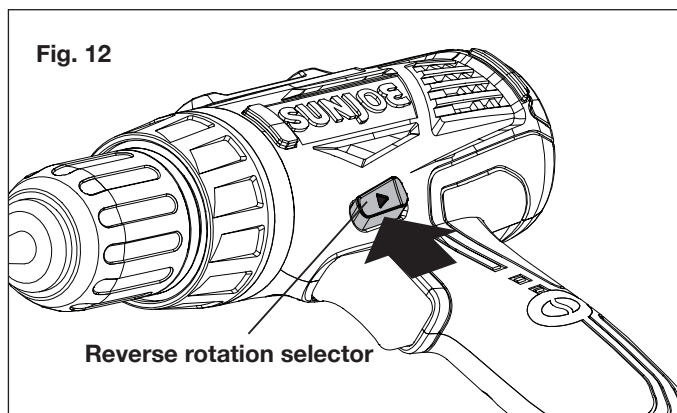

**NOTE:** The drill/driver will not run unless the direction of rotation selector is pushed fully to the left or right.

**⚠ CAUTION!** To prevent gear damage, always allow the chuck to come to a complete stop before changing the direction of rotation.

**⚠ WARNING!** Battery tools are always in operating condition. Lock the switch when not in use or carrying at your side, when installing or removing the battery pack, and when installing or removing bits.

## Starting + Stopping

The variable speed trigger switch delivers higher speed with increased trigger pressure and lower speed with decreased trigger pressure.

1. Set the direction of rotation selector in the OFF (center lock) position to lock the switch trigger (Fig. 13).
2. Insert the battery in the battery compartment (Fig. 14).

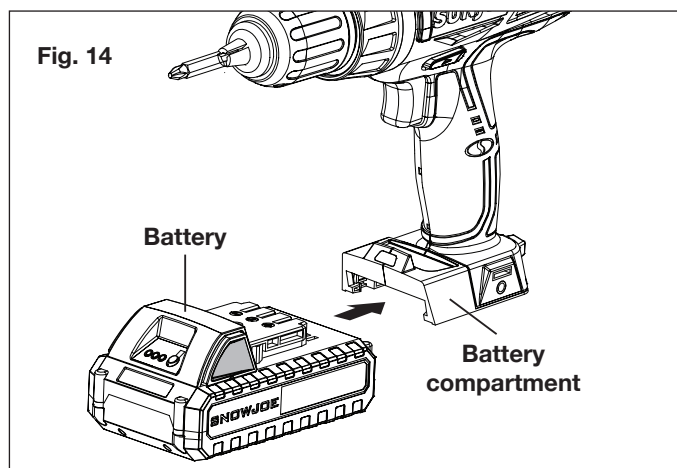

3. To turn the drill ON, depress the trigger switch (Fig. 15).

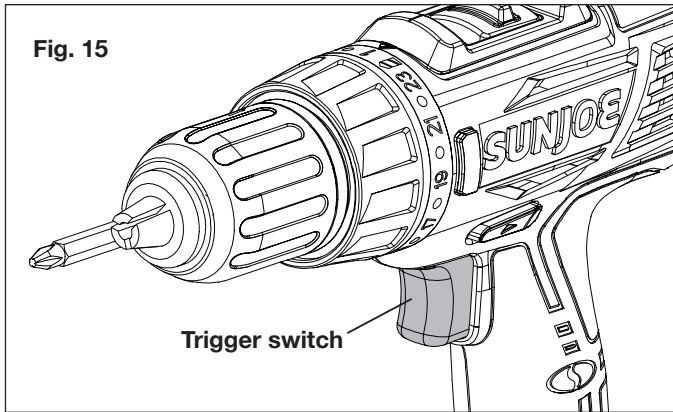

4. To turn it OFF, release the trigger switch and allow the chuck to come to a complete stop (Fig. 15).

**NOTE:** A whistling or ringing noise coming from the switch during use is a normal part of the switch function.

**NOTE:** Running at low speeds under constant usage may cause the drill to become overheated. If this occurs, cool the drill by running it without a load and at full speed.

## Speed Settings

1. Select low speed (1) for applications requiring higher power and torque, such as driving screws and drilling in metal (Fig. 16).
2. Select high speed (2) for fast drilling or driving applications, for drilling in wood or masonry (Fig. 16).

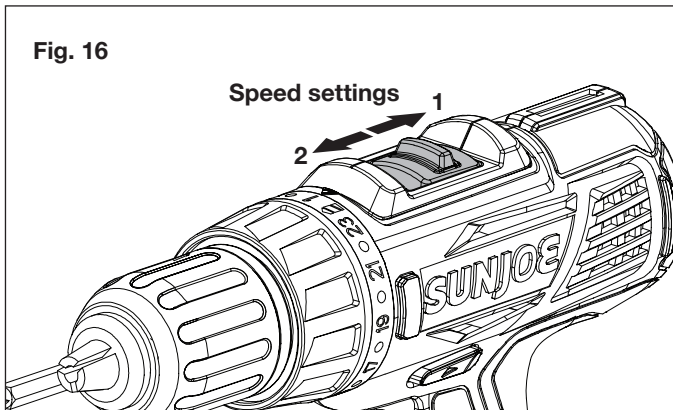

**CAUTION!** Never change speeds while the tool is running. Failure to obey this caution could result in serious damage to the drill.

**NOTE:** If you have difficulty changing from one speed range to the other, turn the chuck by hand until the gears engage.

## Adjusting Torque

Select the proper torque setting by aligning the adjustment ring with the indicator arrow to suit the type of material and size of screw you are using (Fig. 17).

- 1 - 4 For driving small screws
- 5 - 8 For driving screws into soft material
- 9 - 12 For driving screws into soft and hard materials
- 13 - 16 For driving screws into hard wood
- 17 - 20 For driving large screws
- 21 - 23 For heavy drilling
-  For heavy drilling

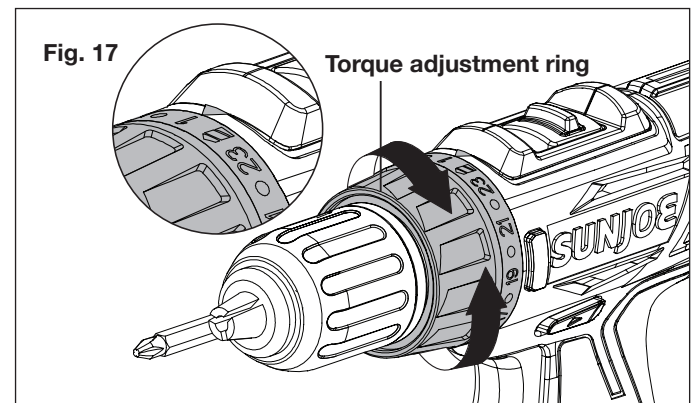

## LED Light

The cordless drill/driver is equipped with an LED light to provide additional lighting for operation in low light conditions. The LED light will turn on when the trigger switch is pressed (Fig. 18).

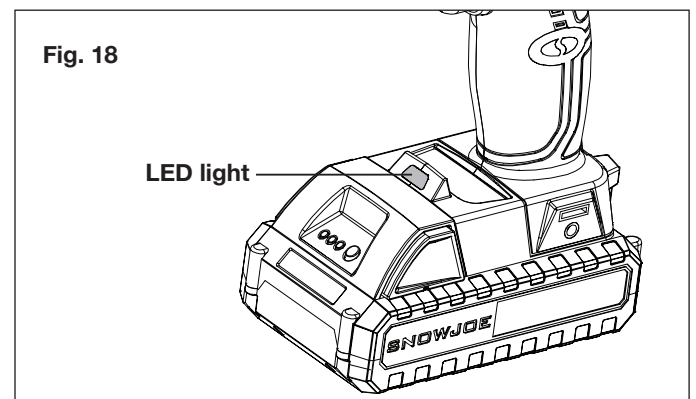

## Drilling/Driving Screws

A level is located on the top of the motor housing to help keep the drill bit level during use (Fig. 19).

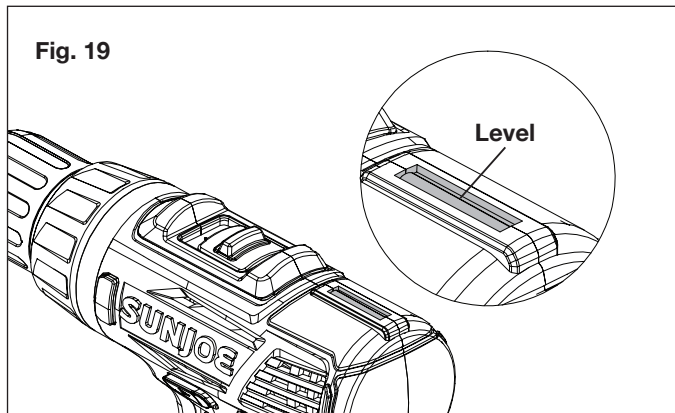

Fig. 19

1. Check the direction of rotation selector for the correct setting (forward or reverse).
2. Select low speed (1) or high speed (2), depending on your application. Refer to Speed Settings and Adjusting Torque.
3. Secure the workpiece in a vise or with clamps to keep it from turning as the bit rotates.
4. Hold the drill firmly and place the bit at the point to be drilled, or where the screw is to be driven.

**⚠WARNING!** Do not drive a screw where there is likely to be hidden wiring behind the surface. Contact with a “live” wire will make exposed metal parts of the tool “live” and possibly shock the operator. If you must drive a screw where hidden wire may be present, always hold tool by insulated gripping surfaces (handle) when performing the operation to prevent a shock to the operator.

5. Depress the switch trigger to start the drill.
6. Move the bit into the workpiece, applying only enough pressure to keep the bit cutting or driving the screw. Do not force the drill or apply side pressure to elongate a hole. Let the tool do the work.

**⚠WARNING!** When drilling, be prepared for binding at bit breakthrough. When these situations occur, drill has a tendency to grab and kick opposite to the direction of rotation and could cause loss of control when breaking through material. If not prepared, this loss of control can result in possible serious injury.

7. When drilling hard, smooth surfaces, use a center punch to mark the desired hole location. This will prevent the bit from slipping off-center as the hole is started.
8. If the bit jams in the workpiece or if the drill stalls, stop the tool immediately. Remove the bit from the workpiece and determine the reason for jamming.

**NOTE:** This drill has an electric brake. When the switch trigger is released, the chuck stops turning. When the brake is functioning properly, sparks will be visible through the vent slots on the housing. This is normal and is the action of the brake.

## Wood + Metal Drilling

For maximum performance, use high speed steel bits for wood or metal drilling. Select drilling mode. Begin drilling at a very low speed to prevent the bit from slipping off the starting point.

### Wood Drilling

1. Increase the speed as the drill bit bites into the material.
2. When drilling through holes, place a block of wood behind the workpiece to prevent ragged or splintered edges on the back side of the hole.

### Metal and Steel Drilling

1. Use a light oil on the drill bit to keep it from overheating. The oil will prolong the life of the bit and increase the drilling action.
2. Maintain a speed and pressure which allows cutting without overheating the bit. Applying too much pressure will:
  - Overheat the drill;
  - Wear the bearings;
  - Bend or burn bits; and
  - Produce off-center or irregular-shaped holes.
3. When drilling large holes in metal, start with a small bit, then finish with a larger bit.

## Cleaning + Maintenance

**⚠WARNING!** When servicing, use only identical replacement parts. Use of any other part could create a hazard or cause product damage.

**⚠WARNING!** To avoid accidents, always disconnect the tool and/or charger from the power supply before cleaning.

Ventilation openings and trigger switch must be kept clean and free of foreign matter. Do not attempt to clean by inserting pointed objects through opening.

**⚠CAUTION!** Avoid using solvents when cleaning plastic parts. Most plastics are susceptible to damage from various types of commercial solvents and can be damaged by their use. Use clean cloths to remove dirt, dust, oil, grease, etc.

## Storage

Store your drill/driver in the tool case and out of reach of children or other untrained persons.

# Battery Caution + Disposal

## Disposal

Should your appliance need replacement after extended use, do not dispose of it with the household refuse, but in an environmentally safe way.



Waste produced by electrical machine items should not be handled like normal household rubbish. Please recycle where recycle facilities exist. Check with your local authority or retailer for recycling advice.

Always dispose of your battery pack according to federal, state, and local regulations. Contact a recycling agency in your area for recycling locations.

**⚠ CAUTION!** Even discharged battery packs contain some energy. Before disposing, use electrical tape to cover the terminals to prevent the battery pack from shorting, which could cause a fire or explosion.

**⚠ WARNING!** To reduce the risk of injury or explosion, never burn or incinerate a battery pack even if it is damaged, dead, or completely discharged. When burned, toxic fumes and materials are emitted into the surrounding atmosphere.

1. Batteries vary according to device. Consult your manual for specific information.
2. Install only new batteries of the same type in your product (where applicable).
3. Failure to insert batteries in the correct polarity, as indicated in the battery compartment or manual, may shorten the life of the batteries or cause batteries to leak.
4. Do not mix old and new batteries.
5. Do not mix Alkaline, Standard (Carbon-Zinc), or Rechargeable (Nickel Cadmium, Nickel Metal Hydride, or Lithium-Ion) batteries.
6. Do not dispose of batteries in fire. The cell of the battery may explode.
7. Batteries should be recycled or disposed of as per state and local guidelines.

# Service + Support

- Drill/driver service must be performed only by qualified repair personnel. Service or maintenance performed by unqualified personnel may result in a risk of injury.
- When servicing a drill/driver, use only identical replacement parts. Follow instructions in the cleaning and maintenance section of this manual. Use of unauthorized parts or failure to follow maintenance instructions may create a risk of shock or injury.
- If your Sun Joe® iON+ 24V-DD-LTE-RM cordless drill/driver requires service or maintenance, please call the Snow Joe® + Sun Joe® customer service center at 1-866-SNOWJOE (1-866-766-9563).

# Model + Serial Numbers

When contacting the company or reordering parts, you will need to provide the model and serial numbers of your product. These are found on the decal affixed to the housing or handle of your cordless a drill/driver. Copy these numbers into the space provided below.

<b>Record the following numbers from the housing or handle of your new product:</b>	
Model #:	
2   4   V   -   D   D   -   L   T   E   -   R   M	
Serial #:	

# Optional Accessories

**⚠ WARNING!** ALWAYS use only authorized Snow Joe® + Sun Joe® replacement parts and accessories. NEVER use replacement parts or accessories that are not intended for use with this cordless drill/driver. Contact Snow Joe® + Sun Joe® if you are unsure whether it is safe to use a particular replacement part or accessory with your cordless drill/driver. The use of any other attachment or accessory can be dangerous and could cause injury or mechanical damage.

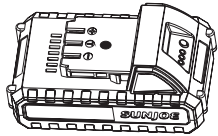
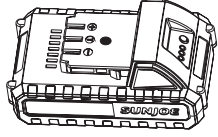
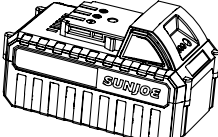
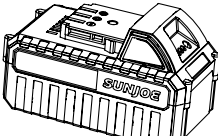
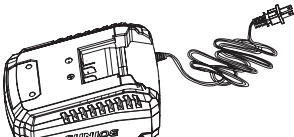
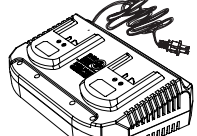
Accessories	Item	Model
	24V iON+ 2.0 Ah Lithium-Ion Battery	24VBAT-LTE
	24V iON+ 2.5 Ah Lithium-Ion Battery	24VBAT-LT
	24V iON+ 4.0 Ah Lithium-Ion Battery	24VBAT
	24V iON+ 5.0 Ah Lithium-Ion Battery	24VBAT-XR
	24V iON+ Lithium-Ion Battery Quick Charger	24VCHRG-QC
	24V iON+ Lithium-Ion Battery Dual Port Charger	24VCHRG-DPC

**NOTE:** Accessories are subject to change without any obligation on the part of Snow Joe® + Sun Joe® to provide notice of such changes. Accessories can be ordered online at [sunjoe.com](http://sunjoe.com) or via phone by contacting the Snow Joe® + Sun Joe® customer service center at 1-866-SNOWJOE (1-866-766-9563).



## SNOW JOE® + SUN JOE® REFURBISHED GOODS WARRANTY

### GENERAL CONDITIONS:

Snow Joe® + Sun Joe® operating under Snow Joe®, LLC warrants this refurbished product to the original purchaser for 90 days against defects in material or workmanship when used for normal residential purposes. If a replacement part or product is needed, it will be sent free of charge to the original purchaser except as noted below.

The duration of this warranty applies only if the product is put to personal use around the household. It is the owner's responsibility to correctly perform all maintenance and minor adjustments explained in the owner's manual.

### HOW TO OBTAIN YOUR REPLACEMENT PART OR PRODUCT:

To obtain a replacement part or product, please visit [snowjoe.com/help](http://snowjoe.com/help) or email us at [help@snowjoe.com](mailto:help@snowjoe.com) for instructions. Please be sure to register your unit beforehand to speed up this process. Certain products may require a serial number, typically found on the decal affixed to the housing or guard of your product. All products require a valid proof of purchase.

### EXCLUSIONS:

- Wearing parts like belts, augers, chains and tines are not covered under this warranty. Wearing parts can be purchased at [snowjoe.com](http://snowjoe.com) or by calling 1-866-SNOWJOE (1-866-766-9563).
- Batteries are covered in full for 90-days from the date of purchase.

Snow Joe® + Sun Joe® may from time to time change the design of its products. Nothing contained in this warranty shall be construed as obligating Snow Joe® + Sun Joe® to incorporate such design changes into previously manufactured products, nor shall such changes be construed as an admission that previous designs were defective.

This warranty is intended to cover product defects only. Snow Joe®, LLC is not liable for indirect, incidental or consequential damages in connection with the use or misuse of the Snow Joe® + Sun Joe® products covered by this warranty. This warranty does not cover any cost or expense incurred by the purchaser in providing substitute equipment or service during reasonable periods of malfunction or non-use of this product while waiting for a replacement part or unit under this warranty. Some states do not allow exclusions of incidental or consequential damages so the above exclusions may not apply in all states. This warranty may give you specific legal rights in your state.

### HOW TO REACH US:

We're here to help Monday through Friday from 9AM to 7PM EST and Saturday and Sunday 9AM to 4PM. You can reach us at 1-866-SNOWJOE (1 866-766-9563), online at [snowjoe.com](http://snowjoe.com), via email at [help@snowjoe.com](mailto:help@snowjoe.com) or tweet us @snowjoe.

### EXPORTS:

Customers who have purchased Snow Joe® + Sun Joe® products exported from the United States and Canada should contact their Snow Joe® + Sun Joe® distributor (dealer) to obtain information applicable to your country, province or state. If for any reason, you are not satisfied with the distributor's service, or if you have difficulty obtaining warranty information, contact your Snow Joe® + Sun Joe® seller. If in the event your efforts are unsatisfactory, please reach out to us directly.











[sunjoe.com](http://sunjoe.com)